

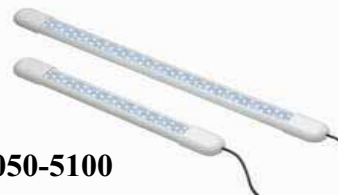

LED Products: Marine Interior Lights

Channel Brite Interior Lighting Kit

- Operates 9-16 Volt DC Systems
- Rated @ 100,000 Hours of Service Life
- Shock and Vibration Proof
- Low Profile Design
- No Heat Given Off by Light
- Attractive End Caps Included to Give Nice Finished Look
- 4 Ft. Power Cord Included for 12v Purposes
- Available in 150, 300, 600, 1200 & 2400mm lengths**



Series P/N 050-5100

20 LED Round Interior Light

- Operates on 12 Volt DC
- Rated @ 50,000 Hours of Service Life
- Sleek Low Profile
- Requires 2.187" Hole
- Shock and Vibration Proof
- Metal Housing & Trim Ring
- 20 LEDs
- Trim colours, black, white, brass & chrome
- LED colours

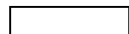

Dimensions:
75mm OD
55mm ID



Series P/N 020-000



Series P/N 017-0000

LED Bunk Light

- Operates on 12 Volt DC
- Rated @ 50,000 Hours of Service Life
- Built in ON/OFF Switch
- For Interior Use Only
- Rotating Head
- 4 LEDs
- Trim colours, black & white
- LED colours



Series P/N 018-0000



Dimensions: L174.5mm
W30.5mm D30.5mm

Flex N lite LED Light Strip

- Operates 9-16 Volt DC Systems
- Rated @ 100,000 Hours of Service Life
- Cool to the Touch
- Flexible Circuit Board
- Self Adhesive Tape Backing
- For Indoor or Outdoor Use
- 39 LEDs
- 600mm Lengths
- Colours available





LED Products: Marine Interior Lights

3 LED Step Surface Mount Light

- Operates 9-16 Volt DC Systems
- 24 Volt Version Available
- Rated @ 200,000 Hours of Service Life
- Shock and Vibration Proof
- Cool to the Touch
- Energy Draw 26 Milliamps
- No Corrosion
- Potted to Seal Out Moisture
- 3 LEDs (available with 5 LED's)
- Trim colours, black, white & chrome
- Colours available



Series P/N 003-0000



Dimensions: L43mm
W16mm D10mm

4 LED Recess Mount Ceiling Light

- Operates on 12 Volt DC
- 24V available
- Draws 60 Milliamps
- Rated @ 50,000 Hours of Service Life
- Recess & Surface Mount Applications
- Sleek Low Profile
- Shock and Vibration Proof
- White Surface Mount Bezel Available
- 4 LEDs
- Trim colours, black, white, chrome, gold
- LED Colours

Dimensions: Series P/N 034-0000
75mm OD
25mm D



Series P/N 004-0000



Series P/N 033-0000



Dimensions:
75mm OD
25mm D

Surface Mount Ceiling Light 3 Watt

- Operates on 12 Volt DC
- 24V available
- Single LED Configuration – 3 Watt
- Draws 475 Milliamps
- Rated @ 50,000 Hours of Service Life
- Surface Mount Application
- Sleek Low Profile
- Shock and Vibration Proof
- Also available in 1 Watt.
- Trim colours, black, white, silver & brass

4 LED Courtesy Surface Mount Light

- Operates 9-16 Volt DC Systems
- 24 Volt Version Available
- Rated @ 200,000 Hours of Service Life
- Shock and Vibration Proof
- Cool to the Touch
- Energy Draw 26 Milliamps
- No Corrosion
- Potted to Seal Out Moisture
- 4 LEDs (Available in single LED)
- Trim colours, black, white & chrome
- Colours available



Dimensions:
39.8mm L
20.8mm W
14.5mm D



LED Products: Marine Interior & Exterior lights.



62800WU
MODEL SL6200 white led interior & utility lamp



20800WU
2" Round white led interior & utility lamp

Dimensions L150mm W50mm D40mm

White Dragon LED

42800WU
MODEL SL4200 white led interior & utility lamp



25800WU
2 1/2" Round white led interior & utility lamp

Dimensions L100mm W47mm D40mm

- SL4800: 6 WHITE DRAGON™ LED light design.
- SL8800: 4 WHITE DRAGON™ LED light design.
- Ultrasonically sealed polycarbonate lens and housing.
- Operating range 14 volts.
- Patented reflector and optical lens design maximizes light output
- Meets SAE J593 photometric requirements
- Isolated standard plug and wiring eliminates connector corrosion at the housing.



LED Compartment Light With Switch

Series P/N 061-0000



- Operates 12&24Volt DC System
- 6 LED Configuration
- Draws 60 Milliamps
- Rated at 50,000 hours of Service life
- Shock and Vibration Proof
- Built-In Push Lens for On/Off Position
- Can be Mounted Surface or Flush Mount (bezel can be removed)
- Two Hole Mount
- UV Resistant Materials
- Two 6" Wire Leads
- Flange Depth .250
- Trim Colours black, white gold and Chrome



Dimensions:
140mm L
92mm W
32mm D

Surface Mount White LED

- Operates 9-16 Volt DC Systems
- Rated @ 100,000 Hours of Service Life
- Shock and Vibration Proof
- Cool to the Touch
- Energy Draw 50 Miliamps
- No Corrosion
- 2 LEDs
- Optional chrome trim
- 24V Available

Dimensions:
66mm L
48mm W
17mm L
(W/O trim)



Series P/N 200-2500

Cabinet LED Lights



Under Cabinet 3 puck White LED kit

- Operates 12 Volt
- Rated @ 50,000 Hours of Service Life
- Each puck has 30 LED's
- Can be recess or surface mounted
- Energy Draw 120 Miliamps
- Puck is 50mm across & 18mm deep.
- Bezel ring 65mm
- Cool to the Touch
- Perfect for use in cabinets & ceilings.



Series P/N 707-X230

Ultra-thin round puck White LED kit

- Operates 12 Volt
- Rated @ 50,000 Hours of Service Life
- Each puck has 19 LED's
- Surface mounted
- Energy Draw 120 Miliamps
- Cool to the Touch
- Perfect for use in cabinets & ceilings.



Series P/N 707-5290

Ultra-thin under cabinet strip White LED kit

- Operates 12 Volt
- Rated @ 50,000 Hours of Service Life
- Each puck has 19 LED's
- Surface mounted
- Energy Draw 120 Miliamps
- Cool to the Touch
- Each self-adhesive strip has 12 LED's
- Perfect for use in covers & cabinets.
- Kit has 4 strips giving a total 1220mm in length

Series P/N 707-5120



Ultra-thin square puck White LED kit

- Operates 12 Volt
- Rated @ 50,000 Hours of Service Life
- Each puck has 18 LED's
- Surface mounted
- Energy Draw 120 Miliamps
- Cool to the Touch
- Perfect for use in cabinets & ceilings.



Series P/N 707-5480

Marine Exterior LED Lights

Navigation LED Lights

- Sold as a Pair
- Operates 9-16 Volt DC Systems
- 3 LED Configuration
- For Powerboats Under 20 Meters (65.6 ft.)
- 50,000 Hours of Service Life
- Requires .375" Hole
- Energy Draw 65 Milliamps
- Transparent Lens
- Cool to the Touch
- Stainless Steel Housing
- Hard Wire Leads
- Permanent Snap On Cover
- Available in polished steel or white



Serial N/O 554
LED side lights
Vertical mount



Serial N/O 550
LED combination side lights
Deck mount



Serial N/O 552
LED side lights
Deck mount

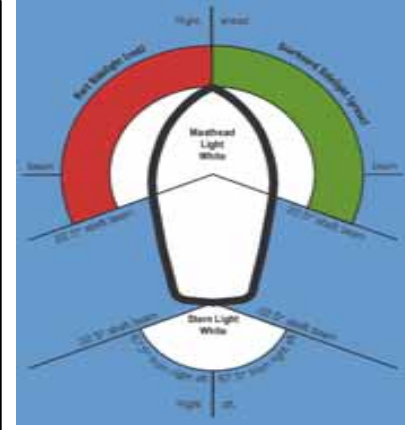

All-Round Stern LED Lights

- Operates 9-16 Volt DC Systems
- For Powerboats Under 20 Meters (65.6 ft)
- Single LED Configuration
- 50,000 Hours LED Service Life
- Energy Draw 180 Milliamps
- Vibration and Shock Proof
- Sealed Circuitry
- Corrosion Resistant Construction
- Durable Stainless Steel Pole
- Easily Installed on New and Used Boats
- No Change in Current Switch Required
- Certified Ignition Protected
- IMCI Certified for ISO #8846

All-Round LED Pedestal Mount Stern Light

Serial N/O 500

Sizes Available:
100mm
200mm
300mm



All-Round LED Plug-in Mount Stern Light

Serial N/O 512

Easy Pull-Up/Push-Down Hand Operations

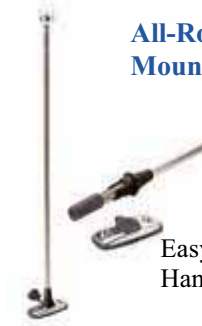

Battery Navigation LED Lights

- Requires 4 "AA" Batteries (Not Included)
- Molded One Piece Body Construction
- Shock Resistant Neoprene Accents
- Incandescent or LED Available
- Rated at 100,000 Hours LED Service Life
- LED Uses 90% Less Energy than Incandescent
- Sealed Heavy Duty On/Off Switch
- Insert Molded Brass Threaded Mounting Bushings
- Removable Lamp Carriage Assembly

Serial N/O 560



Serial N/O 50X

Powerlight Motorized LED Stern Light.

Manually operated Available.



Serial N/O 501 All-Round LED Fold Down Stern Light



Marine Exterior Lights

HID Gas-Discharge

Dimensions: W 104mm H 94mm D 150mm

In Built Duetsch connector



ABL520 Xenon: HID Gas-Discharge work light with built in Duetsch connector. Internal ballast, compact and durable withstanding up to 15gm (Vibration). Available in flood, trapezoid and spot lens patterns.

Suitable for the marine industry. (Stainless steel bracket available).

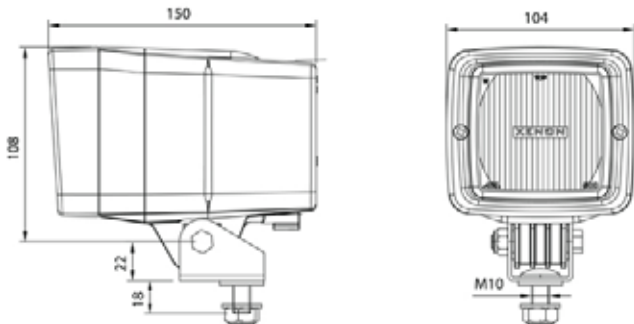

Halogen Lights



(Stainless steel bracket available).

ABL510: Compact work light with integrated Duetsch connector. Suitable for the marine industry. 24V globe included

Dimensions: W 104mm H 94mm D96mm



Dimensions: W 155mm H 104mm D 96mm

ABL1530: Twin beam work lights with twin axis mount. 12V Globes included.

(Stainless steel bracket available).



Dimensions: W 154mm

ABL569: Rubber body work light. Globe not included

Marine General Products



Docking, Hull, Back-up Lights

- Operates 12 Volt DC Systems
- 50 Watt Halogen Lamp
- Draws 4 Amps Each
- Sealed Built-in Rear Heat Sink
- Thermal Insulated Wires
- Pyrex Optical Lens
- Spring Loaded Lamp Assembly
- Removable Lens Cover
- Water Tight Gaskets Included
- **Patent #D472654**
- **Available in White, Black or Mirror Polished.**



Serial N/O 580



Electronic Horns



3-White portable LED battery Light



All-Round LED Ski Light

- Operates 9-16 Volt Systems
- Single LED Configuration
- For Powerboats Under 20 Meters (65.6 ft.)
- 50,000 Hours of Service Life
- Energy Draw 120 Milliamps
- Transparent Lens and Globe
- Shock and Vibration Proof
- Fixed Mounting Base

Serial N/O 503



- Operates 9-16 Volt DC Systems
- Rated @ 100,000 Hours of Service Life
- Requires 11/16" (.687) Hole
- Shock and Vibration Proof
- Cool to the Touch
- No Corrosion
- Rated for Underwater Use
- 1 LED
- **Patent #D439350**

LED single bulkhead recess mount.

