

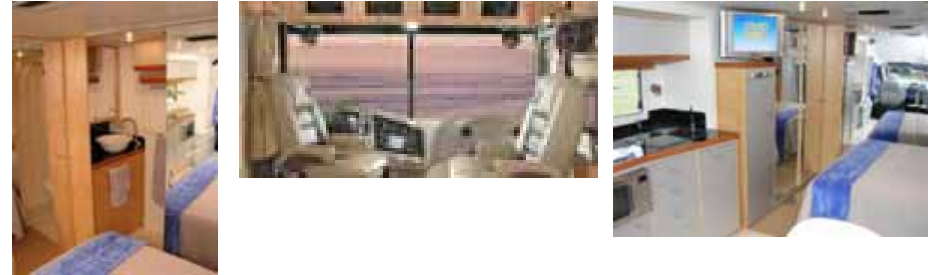

Product Catalogue

LED Interior Lights



LED Exterior Lights



Work Lights HID/Halogen



Marine Lights



LED Home Interior Lights



Index:

2. Index
3. Interior Lights (LED).
4. Interior Lights (LED) cont.
5. Cabinet Lights (LED).
6. Interior & Clearance Lights (LED).
7. Clearance Lights (LED) cont.
8. Clearance Lights (LED) cont.
9. Clearance Lights (LED) cont.
10. Stop/Tail & indicator Lights (LED).
11. General Lights (LED).
12. Revolutionary Rail lite LED lighting system.
13. Halogen Work Lights.
14. Gas-Discharge HID Work Lights.
15. General Work Lights.
16. Marine Interior Lights (LED).
17. Marine Interior Lights (LED) cont.
18. Marine Interior & Exterior Lights (LED)
19. Cabinet Lights (LED).
20. Marine Navigation & Stern Lights (LED)
21. Marine Exterior Lights (HID & Halogen).
22. General Marine Products.





LED Products: Interior Lights

Channel Brite Interior Lighting Kit

- Operates 9-16 Volt DC Systems
- Rated @ 100,000 Hours of Service Life
- Shock and Vibration Proof
- Low Profile Design
- No Heat Given Off by Light
- Attractive End Caps Included to Give Nice Finished Look
- 4 Ft. Power Cord Included for 12v Purposes
- Available in 150, 300, 600, 1200 & 2400mm lengths**

Series P/N 050-5100

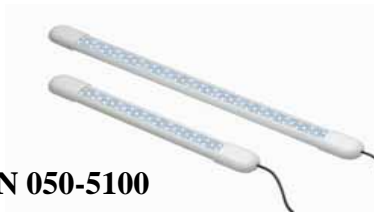

20 LED Round Interior Light

- Operates on 12 Volt DC
- Rated @ 50,000 Hours of Service Life
- Sleek Low Profile
- Requires 2.187" Hole
- Shock and Vibration Proof
- Metal Housing & Trim Ring
- 20 LEDs
- Trim colours, black, white, brass & chrome
- LED colours

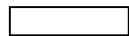

Dimensions:
75mm OD
55mm ID



Series P/N 020-000



Series P/N 017-0000

LED Bunk Light

- Operates on 12 Volt DC
- Rated @ 50,000 Hours of Service Life
- Built in ON/OFF Switch
- For Interior Use Only
- Rotating Head
- 4 LEDs
- Trim colours, black & white
- LED colours

Series P/N 018-0000



Dimensions: L174.5mm
W30.5mm D30.5mm

Flex N lite LED Light Strip

- Operates 9-16 Volt DC Systems
- Rated @ 100,000 Hours of Service Life
- Cool to the Touch
- Flexible Circuit Board
- Self Adhesive Tape Backing
- For Indoor or Outdoor Use
- 39 LEDs
- 600mm Lengths
- Colours available





LED Products: Interior Lights

3 LED Step Surface Mount Light

- Operates 9-16 Volt DC Systems
- 24 Volt Version Available
- Rated @ 200,000 Hours of Service Life
- Shock and Vibration Proof
- Cool to the Touch
- Energy Draw 26 Milliamps
- No Corrosion
- Potted to Seal Out Moisture
- 3 LEDs (available with 5 LED's)
- Trim colours, black, white & chrome
- Colours available



Series P/N 003-0000



Dimensions: L43mm
W16mm D10mm

4 LED Recess Mount Ceiling Light

- Operates on 12 Volt DC
- 24V available
- Draws 60 Milliamps
- Rated @ 50,000 Hours of Service Life
- Recess & Surface Mount Applications
- Sleek Low Profile
- Shock and Vibration Proof
- White Surface Mount Bezel Available
- 4 LEDs
- Trim colours, black, white, chrome, gold
- LED Colours

Dimensions: Series P/N 034-0000
75mm OD
25mm D



Series P/N 004-0000



Series P/N 033-0000



Dimensions:
75mm OD
25mm D

Surface Mount Ceiling Light 3 Watt

- Operates on 12 Volt DC
- 24V available
- Single LED Configuration – 3 Watt
- Draws 475 Milliamps
- Rated @ 50,000 Hours of Service Life
- Surface Mount Application
- Sleek Low Profile
- Shock and Vibration Proof
- Also available in 1 Watt.
- Trim colours, black, white, silver & brass

4 LED Courtesy Surface Mount Light

- Operates 9-16 Volt DC Systems
- 24 Volt Version Available
- Rated @ 200,000 Hours of Service Life
- Shock and Vibration Proof
- Cool to the Touch
- Energy Draw 26 Milliamps
- No Corrosion
- Potted to Seal Out Moisture
- 4 LEDs (Available in single LED)
- Trim colours, black, white & chrome
- Colours available



Dimensions:
39.8mm L
20.8mm W
14.5mm D



Cabinet LED Lights



Under Cabinet 3 puck White LED kit

- Operates 12 Volt
- Rated @ 50,000 Hours of Service Life
- Each puck has 30 LED's
- Can be recess or surface mounted
- Energy Draw 120 Milliamps
- Puck is 50mm across & 18mm deep.
- Bezel ring 65mm
- Cool to the Touch
- Perfect for use in cabinets & ceilings.



Series P/N 707-X230

Ultra-thin round puck White LED kit

- Operates 12 Volt
- Rated @ 50,000 Hours of Service Life
- Each puck has 19 LED's
- Surface mounted
- Energy Draw 120 Milliamps
- Cool to the Touch
- Perfect for use in cabinets & ceilings.



Series P/N 707-5290

Ultra-thin under cabinet strip White LED kit

- Operates 12 Volt
- Rated @ 50,000 Hours of Service Life
- Each puck has 19 LED's
- Surface mounted
- Energy Draw 120 Milliamps
- Cool to the Touch
- Each self-adhesive strip has 12 LED's
- Perfect for use in covers & cabinets.
- Kit has 4 strips giving a total 1220mm in length

Series P/N 707-5120



Ultra-thin square puck White LED kit

- Operates 12 Volt
- Rated @ 50,000 Hours of Service Life
- Each puck has 18 LED's
- Surface mounted
- Energy Draw 120 Milliamps
- Cool to the Touch
- Perfect for use in cabinets & ceilings.



Series P/N 707-5480

LED Products: Interior & Clearance Lights



- White LED light design
- Ultrasonically sealed polycarbonate lens and housing
- Operating range 12-24 volts
- Marine rated



40800WU
4" Round white led interior & utility lamp



20800WU
2" Round white led interior & utility lamp



25800WU
2 1/2" Round white led interior & utility lamp

62800WU
MODEL SL6200 white led interior & utility lamp



Dimensions L150mm W50mm D40mm

82800WU
MODEL SL8200 white led interior & utility lamp



Dimensions
160mm L
55mm W
35mm D



42800WU
MODEL SL4200 white led interior & utility lamp

Dimensions L100mm W47mm D40mm

LED Compartment Light With Switch

Series P/N 061-0000



- Operates 12&24Volt DC System
- 6 LED Configuration
- Draws 60 Milliamps
- Rated at 50,000 hours of Service life
- Shock and Vibration Proof
- Built-In Push Lens for On/Off Position
- Can be Mounted Surface or Flush Mount (bezel can be removed)
- Two Hole Mount
- UV Resistant Materials
- Two 6" Wire Leads
- Flange Depth .250
- Trim Colours black, white gold and Chrome



Dimensions:
140mm L
92mm W
32mm D

Surface Mount White LED

- Operates 9-16 Volt DC Systems
- Rated @ 100,000 Hours of Service Life
- Shock and Vibration Proof
- Cool to the Touch
- Energy Draw 50 Miliamps
- No Corrosion
- 2 LEDs
- Optional chrome trim
- 24V Available



Dimensions:
66mm L
48mm W
17mm L
(W/O trim)

Series P/N 200-2500



LED Products: Clearance Lights

- Operates 9-16 Volt DC Systems
- 2 LED Configuration
- 100,000 Hours of Service Life
- Sonically Sealed Polycarbonate Lens and Housing
- Shock and Vibration Proof
- P2 P3 Rated
- Impact Resistant
- Energy Draw 50 Milliamps
- Mounted Horizontally Only



Dimensions:
66mm L
48mm W
17mm L



Series P/N 200-0000

- Operates 9-16 Volt DC Systems
- 2 LED Configuration
- 100,000 Hours of Service Life
- Requires 13/32" (.406) Hole
- Stud 3/8" (.375) - 16NC x 3/4" (.75) L
- Sonically Sealed Polycarbonate Lens and Housing
- Shock and Vibration Proof
- P2 P3 Rated
- Impact Resistant
- Energy Draw 50 Milliamps
- Mounted Horizontally Only



Series P/N 201-1100 Amber
200-4400 Red

Dimensions:
66mm L
48mm W
17mm L



- Operates 9-16 Volt DC Systems
- 2 LED Configuration
- 100,000 Hours of Service Life
- Sonically Sealed Polycarbonate Lens and Housing
- Shock and Vibration Proof
- P2 P3 Rated
- Impact Resistant
- Ground Eyelet
- Energy Draw 50 Milliamps
- Mounted Horizontally Only
-



Dimensions:
66mm L
48mm W
17mm L



Series P/N 200-1103 Amber
200-4403 Red



Trim Options

LED Products: Clearance Lights

- Operates 9-16 Volt DC Systems
- Single LED Configuration
- 100,000 Hours of Service Life
- Snap-On/Off Polycarbonate Lens
- Shock and Vibration Proof
- P2 P3 Rated
- 6 " Wire Leads
- Energy Draw 50 Milliamps
- **Built in reflectors**



Dimensions:
67mm L
50mm W
19mm D



Series P/N 202-1100 Amber
202-4400 Red

Dimensions:
395mm L
40mm W
20mm D

- Operates 9-16 Volt DC Systems
- Available in 24Volt
- Rated @ 100,000 Hours of Service Life
- 3-LED Configuration
- Impact Resistant Polycarbonate Housing
- Shock and Vibration Proof
- No Corrosion
- Sealed Marker Lights
- Energy Draw 250 Milliamps
- Interchangeable with Most Manufacturers
- 14.50" Mounting Centers
- Required for Trailers, Campers and Trucks Over 80" in Overall Width



Part N/O 251-1100



- 2 LED light design
- Ultrasonically sealed polycarbonate lens and housing
- Operating range 12-24 volts
- Marine rated
- Patented reflector and lens enables 180° viewing
- Isolated standard plug and wiring eliminates connector corrosion.
- Available in 2 and 2 ½ Inch dia.
- Comes in kit form including rubber mount and wiring plug.
- Depth 24mm for 2 inch and 31.5mm for the 2½



LED Products: Clearance Lights



42100A



42100AC

Lights up **Amber**

Dimensions:
 100mm L
 48mm W
 38mm D

3 LED light design



42100R



42100RC

Lights up **Red**

- Ultrasonically sealed polycarbonate lens and housing
- Operating range 12-24 volts
- **Marine rated**
- Patented reflector and lens enables 180° viewing
- Isolated standard plug and wiring eliminates connector corrosion.
- Available in 2 and 2 ½ Inch dia.
- Comes in kit form including rubber mount and wiring plug.



62100RC

62100R

4 LED light design

Dimensions:
 150mm L
 50mm W
 34mm D

62100A

62100AC

Lights up **Amber**



Lights up **Red**



LED Products: Stop/Tail & Indicator LED Lights



40210R



40210RC

Lights up Red

4" Round

Lights up Red



82210RC

Dimensions
160mm L
55mm W
35mm D



82210R

Lights up Red
Series P/N 251-0000



- Ultrasonically sealed polycarbonate lens and housing
- Operating range 12-38V
- Marine rated
- Patented reflector and lens enables 180° viewing
- Isolated standard plug and wiring eliminates connector corrosion.
- Comes in kit form including rubber mount and wiring plug.



- Operates 9-16 Volt DC Systems
- Available in 24Volt
- 11 LED Configuration
- 100,000 Hours of Service Life
- Sealed Polycarbonate Light Bar
- Energy Draw 250 Milliamps
- Mounted Vertical, Horizontal, or 45 Degrees
- Space / Channel Saver Design
- Impact Resistant

Dimensions: L395mm W40mm D20mm
Part N/O 254-1100



82210A



40210A



82210AC



40210AC



Dimensions
160mm L
55mm W
35mm D



Lights up Amber



4" Round



Mounting options.





LED Products: General Lights

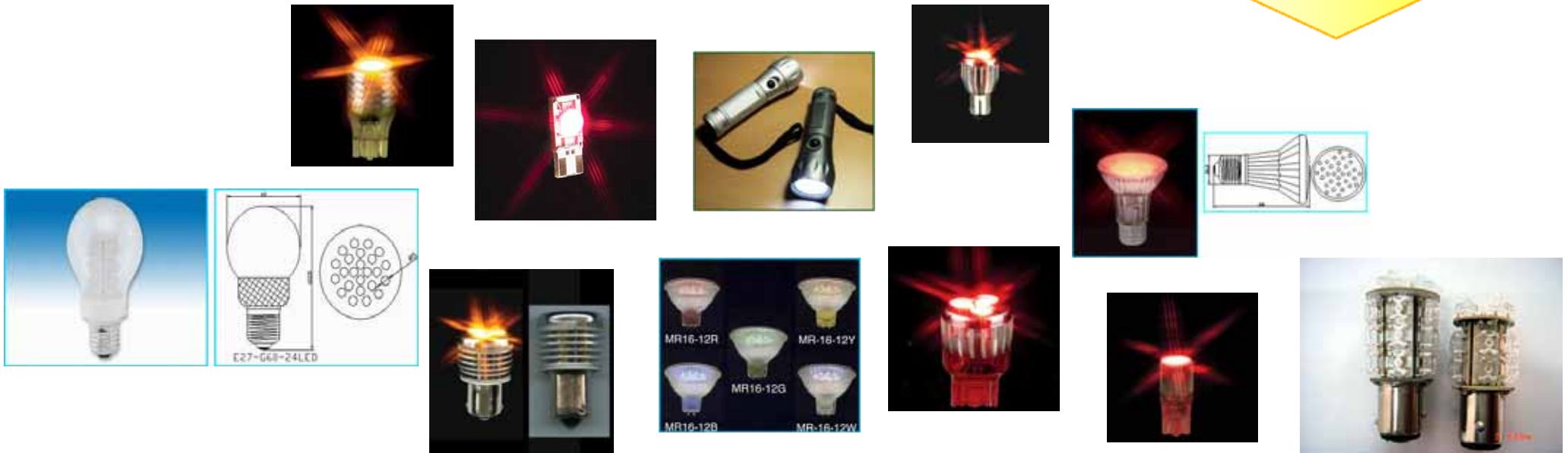

For a complete list of LED globe replacement applications please contact Scanlight Australia on 02 49522231 or scan@acay.com.au. All globe replacements available in LED including 240Volt home applications and all automotive applications.

82800W

White Dragon LED

40800W

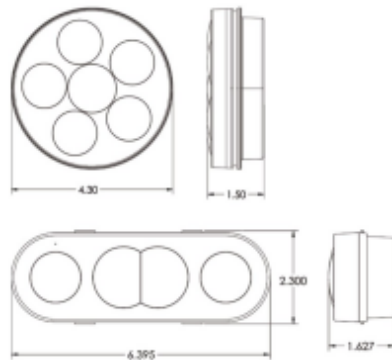

- SL4800: 6 WHITE DRAGON™ LED light design.
- SL8800: 4 WHITE DRAGON™ LED light design.
- Ultrasonically sealed polycarbonate lens and housing.
- Operating range 14 volts.
- Patented reflector and optical lens design maximizes light output
- Meets SAE J593 photometric requirements
- Isolated standard plug and wiring eliminates connector corrosion at the housing.



LED Products: Revolutionary Rail lite LED



New Product Coming soon



RAILLITE™ is a revolutionary patented wireless trailer lighting system. **RAILLITE** incorporates corrosion free electrical conductors and screw mounts directly onto the trailer. Flexible rail couplers allow continuation of the **RAILLITE** around the corners of the trailer. **SNAPLITE™** series marker and clearance lamps simply snap on **RAILLITE** in seconds. saves you time and gives you the versatility of adding, removing and spacing the lamps quickly and easily. No wires, no corrosion, no lamp replacement. Lifetime warranty.

Halogen Work Lights



Dimensions: W 104mm H 94mm D96mm

ABL510: Compact work light with integrated Duetsch connector. Suitable for the mining industry. 24V globe included

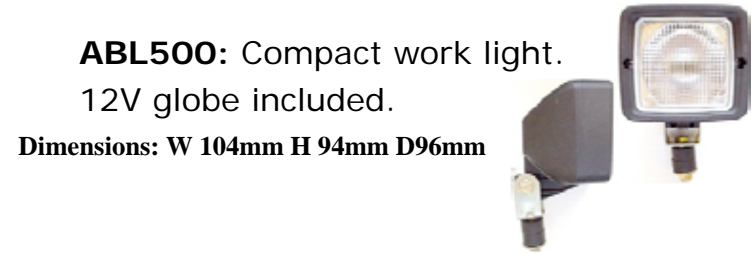

ABL500: Compact work light. 12V globe included.

Dimensions: W 104mm H 94mm D96mm

ABL2500DT: Caterpillar style work light with Duetsch connector. Suitable for the mining industry. 24V globe included.



Dimensions: W 139mm H 139mm D 96mm



ABL1130: Single beam work light with twin axis mounting. 12V Globe included.

Dimensions: W 155mm H 104mm D 96mm



ABL1530: Twin beam work lights with twin axis mount. 12V Globes included.

Dimensions: W 155mm H 104mm D 96mm



ABL2500: Square Caterpillar work light. 12V globe included.

Dimensions: W 139mm H 139mm D 96mm



ABL2560: Caterpillar style work light with anti-vibration dampener. Suitable for the mining industry. 24V globe included.



Dimensions: W 139mm H 139mm D

HID Gas-Discharge Lighting



HID conversion kits. Available in H1,H3,H4 Hi/Low, H7,H9 and H11. All kits come with complete wiring assembly

For more information please call Scanlight on 0408650956 or email scan@acay.com.au



ABL5660: HID Gas-Discharge work light. Internal ballast with heavy duty bracket. Available flood only. 24V globe included



Dimensions: W 139mm H 139mm D 195mm

ABL520Xenon: HID Gas-Discharge work light with built in Duetsch connector. Internal ballast, compact and durable withstanding up to 15g (Vibration). Available in flood, trapezoid and spot lens patterns. **Suitable for the mining industry.**

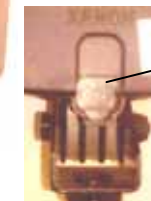

In Built Duetsch connector

Dimensions: W 104mm H 94mm D 150mm



ABL9000 Xenon: Off-Road 4wd light HID Xenon light available in Pencil, Spot and Driving light patterns. Modern design with Aluminized steel reflector

ABL9500 Xenon: Extreme heavy duty high performance worklight designed to function in the most demanding environments such as mining, military and earth moving.



General Work Lights



ABL1220.27: 27 degree flush mount work light. Also available in 5 degree. 12V globe included.

Dimensions: W 155mm H 104mm D

ABL569: Rubber body work light. Globe not included



Dimensions: W 154mm

Dimensions: W 170mm



Dimensions: W 154mm

ABL824: Work light with built in handle and protective metal grill. Globe not included.



AB5: Opaque work light. Globe not included

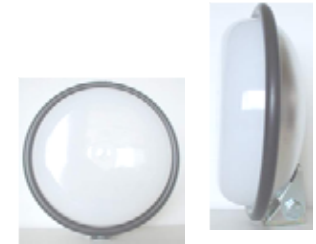

Non Genuine Work Lights



Dimensions: W 156mm D 110mm

SCAN1530: Twin beam work light. 12V globes included. (Non Genuine).

Dimensions: W 155mm H 104mm D 96mm

SCAN1130: Non Genuine single beam work light. 12V globe included





LED Products: Marine Interior Lights

Channel Brite Interior Lighting Kit

- Operates 9-16 Volt DC Systems
- Rated @ 100,000 Hours of Service Life
- Shock and Vibration Proof
- Low Profile Design
- No Heat Given Off by Light
- Attractive End Caps Included to Give Nice Finished Look
- 4 Ft. Power Cord Included for 12v Purposes
- Available in 150, 300, 600, 1200 & 2400mm lengths**

Series P/N 050-5100

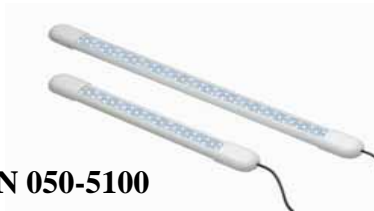

20 LED Round Interior Light

- Operates on 12 Volt DC
- Rated @ 50,000 Hours of Service Life
- Sleek Low Profile
- Requires 2.187" Hole
- Shock and Vibration Proof
- Metal Housing & Trim Ring
- 20 LEDs
- Trim colours, black, white, brass & chrome
- LED colours

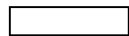

Dimensions:
75mm OD
55mm ID



Series P/N 020-000



Series P/N 017-0000

LED Bunk Light

- Operates on 12 Volt DC
- Rated @ 50,000 Hours of Service Life
- Built in ON/OFF Switch
- For Interior Use Only
- Rotating Head
- 4 LEDs
- Trim colours, black & white
- LED colours

Series P/N 018-0000



Dimensions: L174.5mm
W30.5mm D30.5mm

Flex N lite LED Light Strip

- Operates 9-16 Volt DC Systems
- Rated @ 100,000 Hours of Service Life
- Cool to the Touch
- Flexible Circuit Board
- Self Adhesive Tape Backing
- For Indoor or Outdoor Use
- 39 LEDs
- 600mm Lengths
- Colours available





LED Products: Marine Interior Lights

3 LED Step Surface Mount Light

- Operates 9-16 Volt DC Systems
- 24 Volt Version Available
- Rated @ 200,000 Hours of Service Life
- Shock and Vibration Proof
- Cool to the Touch
- Energy Draw 26 Milliamps
- No Corrosion
- Potted to Seal Out Moisture
- 3 LEDs (available with 5 LED's)
- Trim colours, black, white & chrome
- Colours available



Series P/N 003-0000



Dimensions: L43mm
W16mm D10mm

4 LED Recess Mount Ceiling Light

- Operates on 12 Volt DC
- 24V available
- Draws 60 Milliamps
- Rated @ 50,000 Hours of Service Life
- Recess & Surface Mount Applications
- Sleek Low Profile
- Shock and Vibration Proof
- White Surface Mount Bezel Available
- 4 LEDs
- Trim colours, black, white, chrome, gold
- LED Colours

Dimensions: Series P/N 034-0000
75mm OD
25mm D



Series P/N 033-0000



Dimensions:
75mm OD
25mm D

Surface Mount Ceiling Light 3 Watt

- Operates on 12 Volt DC
- 24V available
- Single LED Configuration – 3 Watt
- Draws 475 Milliamps
- Rated @ 50,000 Hours of Service Life
- Surface Mount Application
- Sleek Low Profile
- Shock and Vibration Proof
- Also available in 1 Watt.
- Trim colours, black, white, silver & brass

4 LED Courtesy Surface Mount Light

- Operates 9-16 Volt DC Systems
- 24 Volt Version Available
- Rated @ 200,000 Hours of Service Life
- Shock and Vibration Proof
- Cool to the Touch
- Energy Draw 26 Milliamps
- No Corrosion
- Potted to Seal Out Moisture
- 4 LEDs (Available in single LED)
- Trim colours, black, white & chrome
- Colours available



Dimensions:
39.8mm L
20.8mm W
14.5mm D



Series P/N 004-0000



LED Products: Marine Interior & Exterior lights.



62800WU
MODEL SL6200 white led interior & utility lamp



20800WU
2" Round white led interior & utility lamp

Dimensions L150mm W50mm D40mm

White Dragon LED

42800WU
MODEL SL4200 white led interior & utility lamp



25800WU
2 1/2" Round white led interior & utility lamp

Dimensions L100mm W47mm D40mm

- SL4800: 6 WHITE DRAGON™ LED light design.
- SL8800: 4 WHITE DRAGON™ LED light design.
- Ultrasonically sealed polycarbonate lens and housing.
- Operating range 14 volts.
- Patented reflector and optical lens design maximizes light output
- Meets SAE J593 photometric requirements
- Isolated standard plug and wiring eliminates connector corrosion at the housing.



LED Compartment Light With Switch

Series P/N 061-0000



- Operates 12&24Volt DC System
- 6 LED Configuration
- Draws 60 Milliamps
- Rated at 50,000 hours of Service life
- Shock and Vibration Proof
- Built-In Push Lens for On/Off Position
- Can be Mounted Surface or Flush Mount (bezel can be removed)
- Two Hole Mount
- UV Resistant Materials
- Two 6" Wire Leads
- Flange Depth .250
- Trim Colours black, white gold and Chrome



Dimensions:
140mm L
92mm W
32mm D

Surface Mount White LED

- Operates 9-16 Volt DC Systems
- Rated @ 100,000 Hours of Service Life
- Shock and Vibration Proof
- Cool to the Touch
- Energy Draw 50 Miliamps
- No Corrosion
- 2 LEDs
- Optional chrome trim
- 24V Available



Dimensions:
66mm L
48mm W
17mm L
(W/O trim)

Series P/N 200-2500

Cabinet LED Lights



Under Cabinet 3 puck White LED kit

- Operates 12 Volt
- Rated @ 50,000 Hours of Service Life
- Each puck has 30 LED's
- Can be recess or surface mounted
- Energy Draw 120 Milliamps
- Puck is 50mm across & 18mm deep.
- Bezel ring 65mm
- Cool to the Touch
- Perfect for use in cabinets & ceilings.



Series P/N 707-X230

Ultra-thin round puck White LED kit

- Operates 12 Volt
- Rated @ 50,000 Hours of Service Life
- Each puck has 19 LED's
- Surface mounted
- Energy Draw 120 Milliamps
- Cool to the Touch
- Perfect for use in cabinets & ceilings.



Series P/N 707-5290

Ultra-thin under cabinet strip White LED kit

- Operates 12 Volt
- Rated @ 50,000 Hours of Service Life
- Each puck has 19 LED's
- Surface mounted
- Energy Draw 120 Milliamps
- Cool to the Touch
- Each self-adhesive strip has 12 LED's
- Perfect for use in covers & cabinets.
- Kit has 4 strips giving a total 1220mm in length

Series P/N 707-5120



Ultra-thin square puck White LED kit

- Operates 12 Volt
- Rated @ 50,000 Hours of Service Life
- Each puck has 18 LED's
- Surface mounted
- Energy Draw 120 Milliamps
- Cool to the Touch
- Perfect for use in cabinets & ceilings.



Series P/N 707-5480

Marine Exterior LED Lights

Navigation LED Lights

- Sold as a Pair
- Operates 9-16 Volt DC Systems
- 3 LED Configuration
- For Powerboats Under 20 Meters (65.6 ft.)
- 50,000 Hours of Service Life
- Requires .375" Hole
- Energy Draw 65 Milliamps
- Transparent Lens
- Cool to the Touch
- Stainless Steel Housing
- Hard Wire Leads
- Permanent Snap On Cover
- Available in polished steel or white



Serial N/O 554
LED side lights
Vertical mount



Serial N/O 550
LED combination
side lights
Deck mount



Serial N/O 552
LED side lights
Deck mount

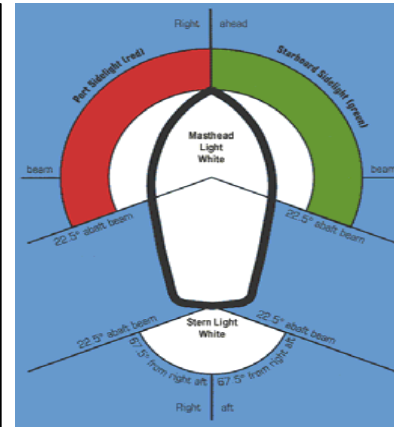

- Operates 9-16 Volt DC Systems
- For Powerboats Under 20 Meters (65.6 ft)
- Single LED Configuration
- 50,000 Hours LED Service Life
- Energy Draw 180 Milliamps
- Vibration and Shock Proof
- Sealed Circuitry
- Corrosion Resistant Construction
- Durable Stainless Steel Pole
- Easily Installed on New and Used Boats
- No Change in Current Switch Required
- Certified Ignition Protected
- IMCI Certified for ISO #8846



All-Round Stern LED Lights

All-Round LED Pedestal Mount Stern Light

Serial N/O 500

Sizes Available:
100mm
200mm
300mm



All-Round LED Plug-in Mount Stern Light

Serial N/O 512

Easy Pull-Up/Push-Down
Hand Operations



Battery Navigation LED Lights

- Requires 4 "AA" Batteries (Not Included)
- Molded One Piece Body Construction
- Shock Resistant Neoprene Accents
- Incandescent or LED Available
- Rated at 100,000 Hours LED Service Life
- LED Uses 90% Less Energy than Incandescent
- Sealed Heavy Duty On/Off Switch
- Insert Molded Brass Threaded Mounting Bushings
- Removable Lamp Carriage Assembly

Serial N/O 560



Serial N/O 50X

Powerlight Motorized LED Stern Light.

Manually operated
Available.



Serial N/O 501 All-Round LED Fold Down Stern Light



Marine Exterior Lights

HID Gas-Discharge

Dimensions: W 104mm H 94mm D 150mm

In Built Duetsch connector



ABL520 Xenon: HID Gas-Discharge work light with built in Duetsch connector. Internal ballast, compact and durable withstanding up to 15grm (Vibration). Available in flood, trapezoid and spot lens patterns.

Suitable for the marine industry. (Stainless steel bracket available).

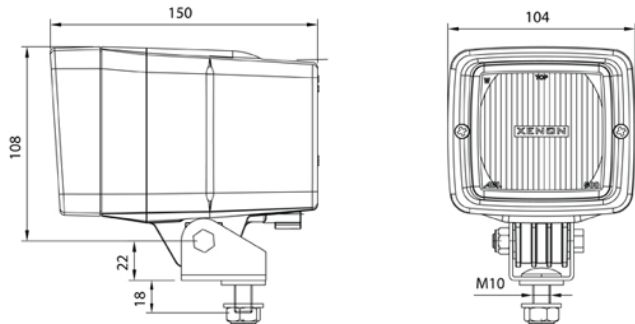

Halogen Lights



(Stainless steel bracket available).

ABL510: Compact work light with integrated Duetsch connector. Suitable for the marine industry. 24V globe included

Dimensions: W 104mm H 94mm D 96mm



Dimensions: W 155mm H 104mm D 96mm

ABL1530: Twin beam work lights with twin axis mount. 12V Globes included.

(Stainless steel bracket available).



Dimensions: W 154mm

ABL569: Rubber body work light. Globe not included

Marine General Products



Docking, Hull, Back-up Lights

- Operates 12 Volt DC Systems
- 50 Watt Halogen Lamp
- Draws 4 Amps Each
- Sealed Built-in Rear Heat Sink
- Thermal Insulated Wires
- Pyrex Optical Lens
- Spring Loaded Lamp Assembly
- Removable Lens Cover
- Water Tight Gaskets Included
- **Patent #D472654**
- **Available in White, Black or Mirror Polished.**



Serial N/O 580



All-Round LED Ski Light

- Operates 9-16 Volt Systems
- Single LED Configuration
- For Powerboats Under 20 Meters (65.6 ft.)
- 50,000 Hours of Service Life
- Energy Draw 120 Milliamps
- Transparent Lens and Globe
- Shock and Vibration Proof
- Fixed Mounting Base

Serial N/O 503



Electronic Horns

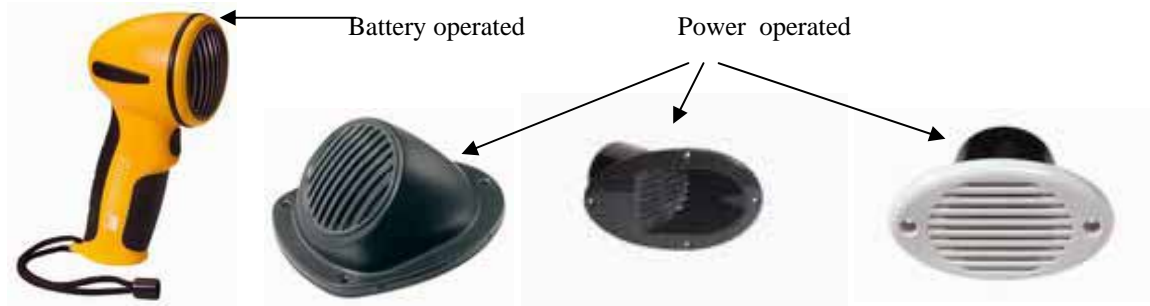

3-White portable LED battery Light



- Operates 9-16 Volt DC Systems
- Rated @ 100,000 Hours of Service Life
- Requires 11/16" (.687) Hole
- Shock and Vibration Proof
- Cool to the Touch
- No Corrosion
- Rated for Underwater Use
- 1 LED
- **Patent #D439350**

LED single bulkhead recess mount.

